

Whatsapp: +86 136 4729 9000
+86 159 7192 0809

BEIBEN TRUCK

Email: info@ceetrucks.com tom@ceetrucks.com

Fuel Tanker Truck



CEEC TRUCKS

Whatsapp: +86 136 4729 9000
+86 159 7124 0000
OWNER'S MANUAL

Preface

Thank you for purchasing CEEC TRUCKS products. For better using your BEIBEN Fuel Tanker Truck, get the best operating performance, we strongly suggest that before the operation process you could read this manual instructions carefully, and to manipulate the program handily.

The manual detailed describes the performance of fuel tanker truck, structure, usage, precautions and maintenance of such knowledge. While showing details of the truck, both pictures and description will together help you get better understanding of how to use truck. Before the operation, the skilled operator should carefully read the contents of the manual.

After master the truck performance characteristics, methods of operation and precautions, then could start to operate this refueling tanker truck. In order to ensure the staff turnover after the operation, and properly use of the truck. This manual book must be properly kept, shall not be lost and damage.



CEE C TRUCKS ----CEE C TRUCKS

Whatsapp: +86 136 4729 9000
+86 159 7192 0800

Contents

Chapter 1. General Description.....	5
Chapter 2, Main Technical Data	6
Chapter 3, Fuel Pump & Fuel Dispenser	7
Chapter 4, Fuel Tanker Truck Structure Components	9
i ,Fuel Tanker Structure Components	9
ii ,Fuel Pipeline Structure Components	11
Chapter 5, Fuel Tanker Truck Working Principles	13
i ,How are the fuel trucks working?.....	13
ii ,What is the main component for truck?.....	13
iii, How to operate fuel tanker trucks?. (Very Important).....	14
Chapter 6, Others for Attention	20
i ,Precautions for Use	20
ii ,Maintenance	21
iii, Spare Parts List	21

Chapter 1. General Description

CEEC TRUCKS Fuel Tanker Truck based on type II Beiben chassis model ND1253B45J, fuel tanker capacity could up to 20,000liters, mainly used for fuel storage and transportation, and the working aerial can be gasoline station, factory, oil field and other areas of need.

*The vehicle designed to fully rely on the advantages of the original Beiben 6*4 truck chassis, fully consider the product's convenience and reliability. The fuel tanker material is international standard carbon steel, both internal and external with anti-rust painting, which can effective to avoid rusting. As for tank capacity, this can be up to 20CBM and very big enough to cover all customers' fuel transport requirement.*

The Beiben Fuel Tanker Truck equipped with Liquidometer, rear climbing ladder, Euro standard valves & Manhole, side & rear guard plate and fire extinguisher to help keeping the trucks safety. Cab for the single-row Air Suspension seat and sleeper, comfortable driving feeling. Therefore, the vehicle is an ideal Fuel Tanker Truck mainly for fuel storage & fuel transportation.



(Preview for your Beiben 20CBM Fuel Tanker Trucks)

Chapter 2, Main Technical Data

Basic parameter:

Items		20CBM BEIBEN Fuel Tanker Truck
S I Z E	Outer Dimension (L×W×H) (mm)	9800x2500x3050
	Wheelbase (mm)	4500+1350
Kerb Weight (kg)		12000
G E A R	Gearbox brand	FAST
	Model	9-shift gearbox
	Type	Manual
Cab capacity (includes driver)		2
E N G I N	Brand	BEIBEN
	Model	WP7.300E30
	Type	Six cylinder inline, four stroke, water-cool, turbocharged Inter-cooling, diesel
	Rating Power (kW/HP)	220/300

Note: 1. The vehicle height includes Rear Climbing Ladder.

2. We keep the right to revise the parameters on the list above.

Water Tanker basic parameter list

Items		Parameter	
Fuel tanker	Capacity (Liters)	20000	
	Material	Standard Carbon Steel	
	Painting	Internal	With anti-rust painting
		External	Light Green painting
	Special Equipment	Liquidometer	Equipped on side of tank
		Valves	Equipped on side of tank
		Climbing Ladder	Equipped at rear of tank
Safety Guard		Equipped on top of tank	
Fuel Pump	Model	80YHCB-60	
	Fuel Flow Rate (m ³ /h)	60	
	Working Pressure (MPa)	0.6	
	Revolving Speed (r/min)	900	
	Self-Suction Height (m)	6	
	Rated Power (kw)	7.5	

Chapter 3, Fuel Pump & Fuel Dispenser

Brief introduction of 80YHCB-60 fuel pump:

Beiben fuel tanker truck use TOP Chinese brand Fuel Pump and pump model is 80YHCB-60. The pump is newly produced National Patent Products which based on many years' independent developing & production of arc gear pump. Also the pumps comply with national standards JB/T6434-92. Advanced features for the pump showing as below: Simple Structure, Smooth Operation, High Efficiency and Reliable Operation.

Below is overview for 80YHCB-60 model fuel pump:

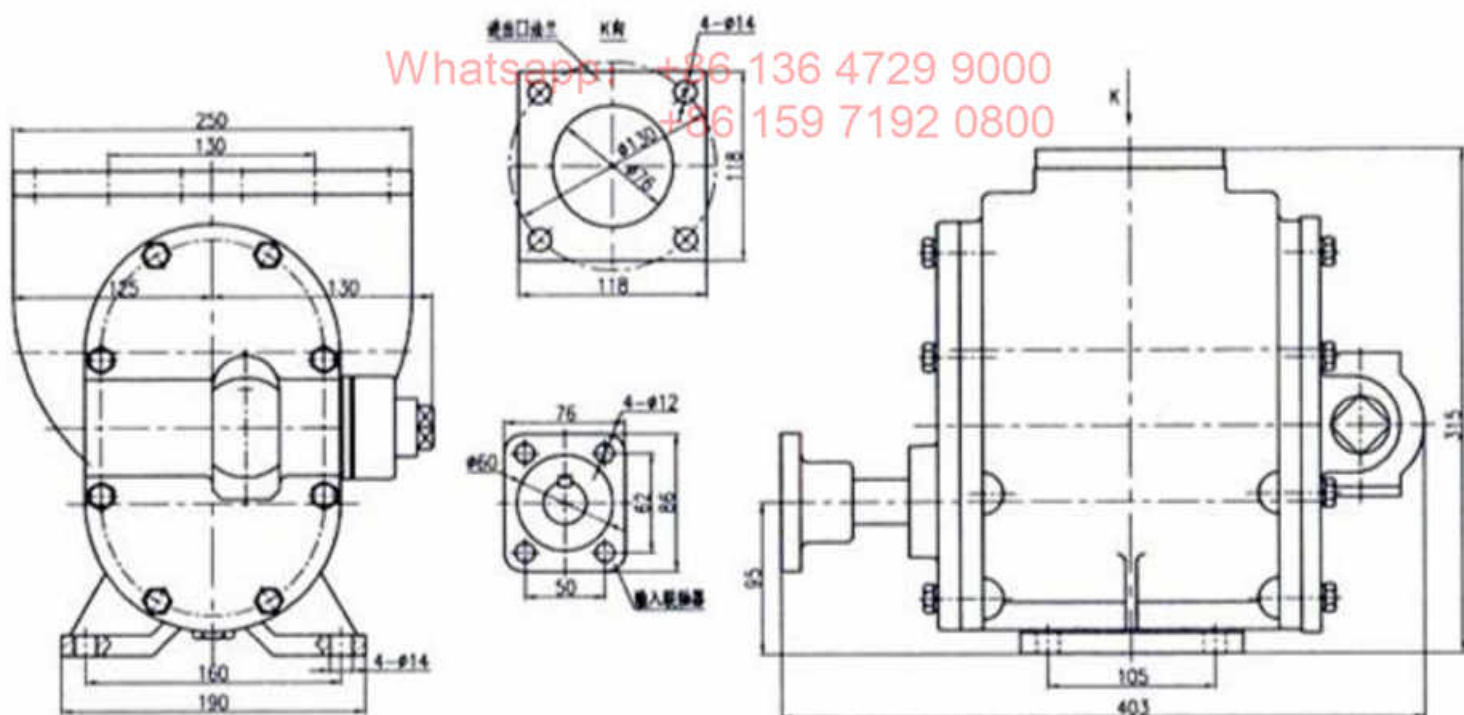

How to Installation & Maintenance 80YHCB-60 fuel pump:

Items	Notification	
1	Usage	<ol style="list-style-type: none"> 1. Installed on Fuel Tanker Truck 2. Installed on Fuel Storage House
2	What need to pay attention while installed on fuel tanker truck	<ol style="list-style-type: none"> 1. The pump get power from PTO 2. The pump is installed in hanging bracket under chassis frame 3. Pumping-In pipeline should match with pump hole, and max. suction height less than 7m 4. On working condition, the pressure gauge less than 0.5MPa, and vacuum gauge less than -0.08MPa
3	Before start working	<ol style="list-style-type: none"> 1. Test the shaft valve direction of rotation 2. Test the Fittings and Flange sealing 3. Test all valves
4	Cleaning suggestion	<ol style="list-style-type: none"> 1. Washing the filter have a month, so to avoid any block 2. Adjust the discharging pressure of safety valve
5	Pump revolution speed suggestion	The pump revolution speed should be from LOW to HIGH, and speed up slowly. Not allowed any over revolution speed or any instability speed
6	Watching pressure gauge & vacuum gauge while pump working	<ol style="list-style-type: none"> 1. When pressure gauge higher, means the lifting is over height or the pumping-out pipeline is blocked 2. When vacuum gauge high, means the suction is over distance or the pumping-in pipeline is blocked
7	Maintenance for cold weather and not working	Discharging all storage inside pump, which can avoid frost crack
8	Maintenance for long-term use	Treated with anti-rust processing and keeping properly
9	Maintenance for bearings	Filling calcium grease every half year
10	Pipeline installation suggestion	The pipeline should be installed at proper height and position
11	Stop working suggestion	When stop the truck, firstly disconnect the PTO handle, secondly close the inlet & outlet valve of the fuel pump
12	Start working suggestion	When no medium inside the fuel pump, strictly forbidden starting

Chapter 4, Fuel Tanker Truck Structure Components

i ,Fuel Tanker Structure Components

Overview for BEIBEN fuel tanker truck technical drawing:

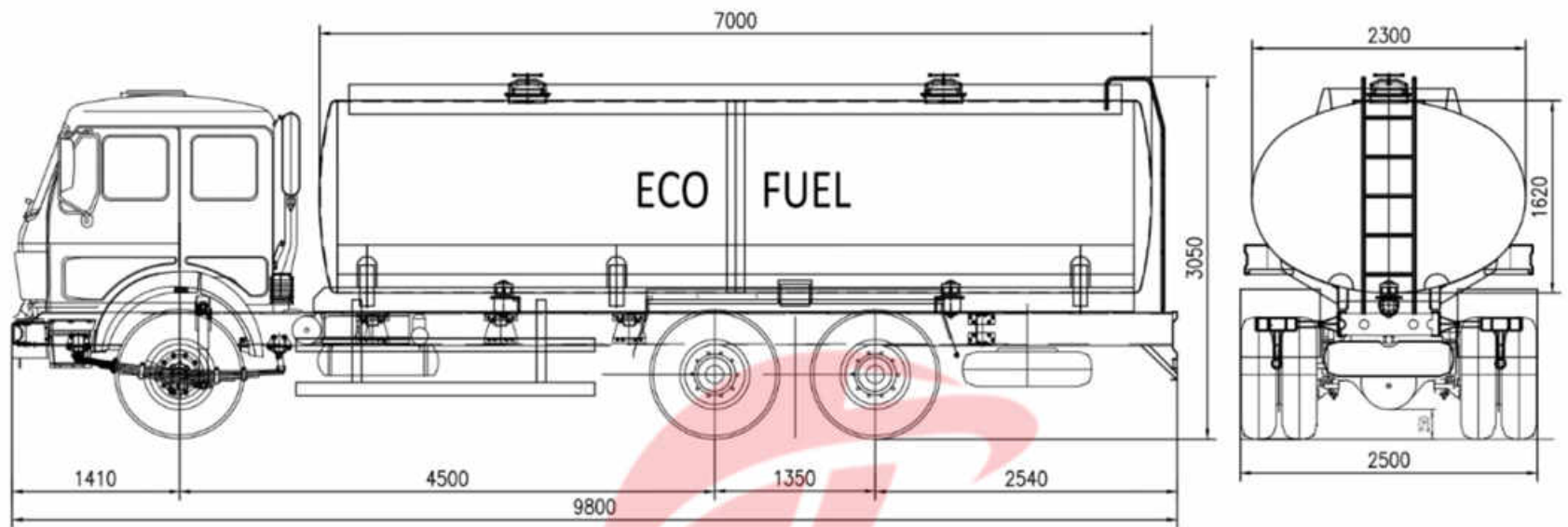

Above drawing show that there are safety-guards at two sides & rear; on top of tank equipped two Euro standard Manholes, also pipeline & box on two sides; at rear of tank equipped climbing ladder. The whole fuel tank is **oval shape**:

Top of the Tank: Antiskid plate and 2 sets Euro standard manhole cover

2 sets Euro standard manhole covers with Key (Top of tank)



Whatsapp: +86 135 4729 9000
+86 159 7192 0800

Antiskid Plate for safety (Top of tank)

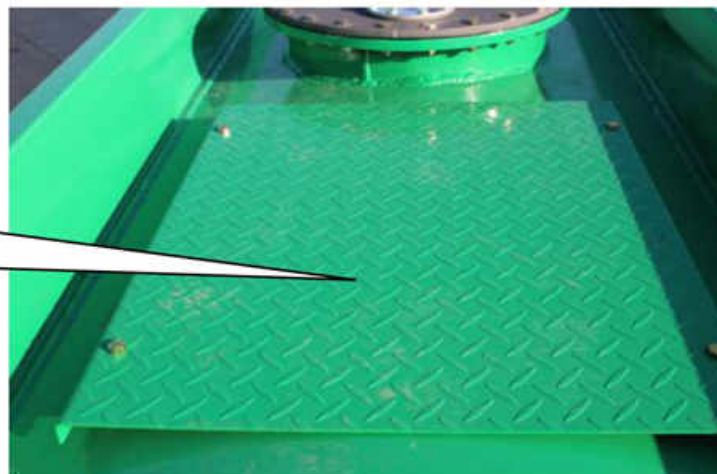

Rear of the Tank: Working Platform, Climbing Ladder, Safety Guard & Pipeline Container



Side of the Tank:

Left Side: Tool Box, Pipeline storage box & Fire-extinguisher storage box



Right Side: Tool Box, Pipeline storage box & Fire-extinguisher storage box

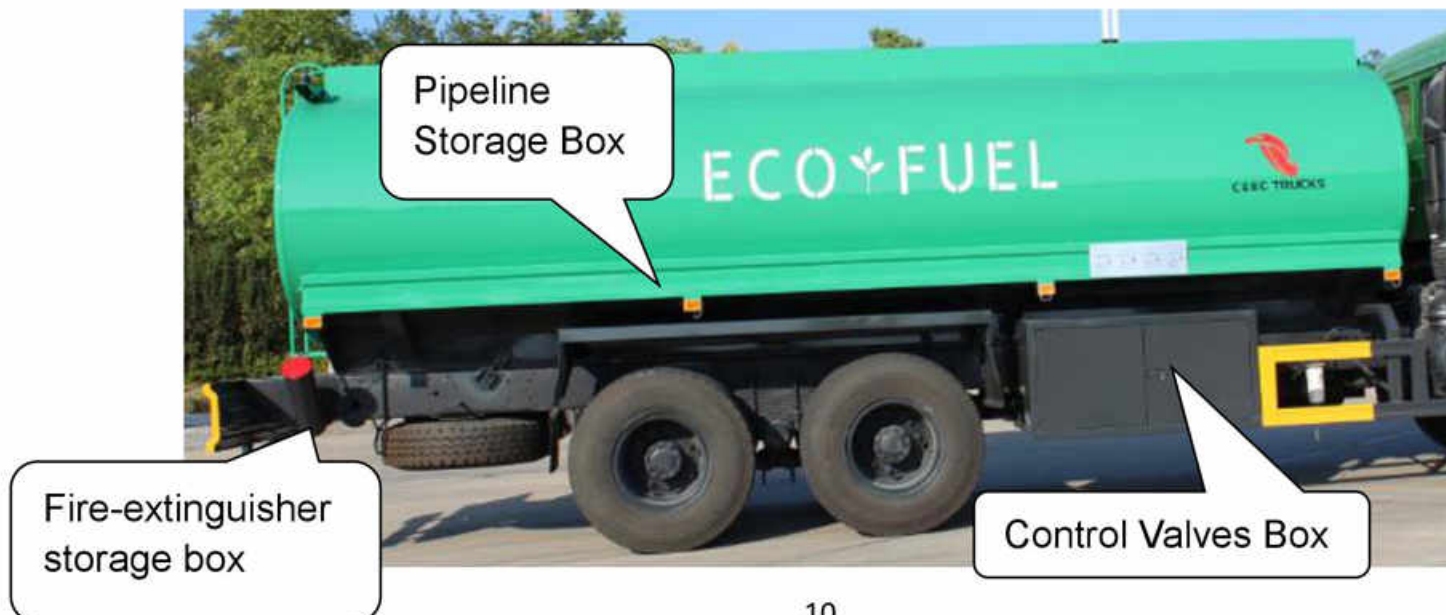

Fire-extinguisher storage box (Two sides) & 3kg powder fire-extinguisher (2 sets)

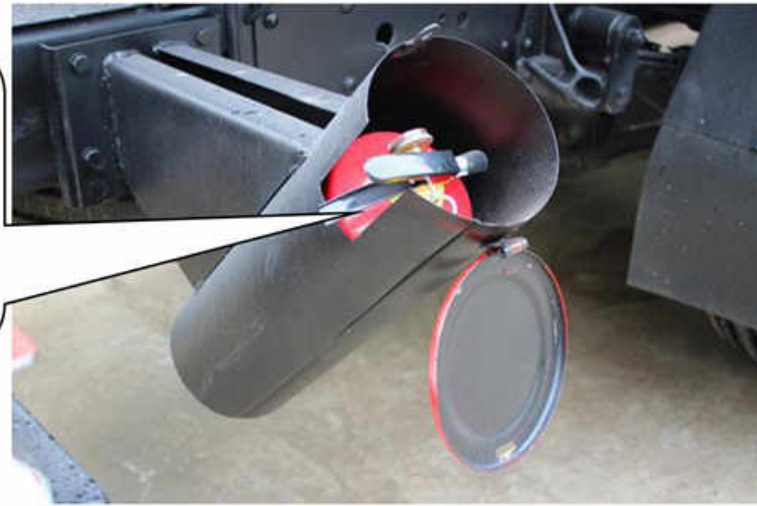

Driver's side of the Tank: Fuel Valves

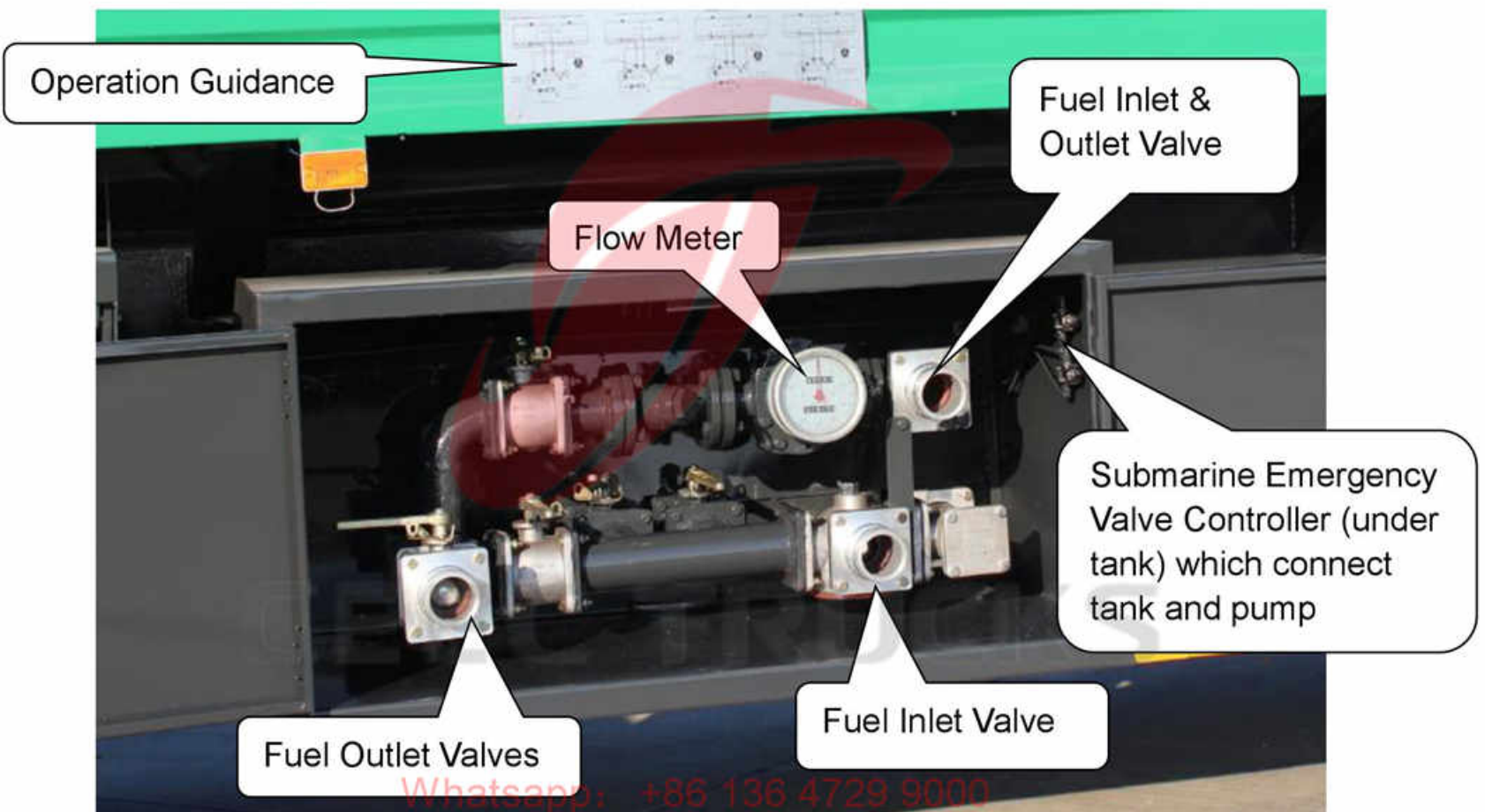

Whatsapp: +86 136 4729 9000
+86 159 7192 0800

ii, Fuel Pipeline Structure Components

Pipeline is to fuel truck what blood vessel is to human body! The fuel tanker trucks pipeline system is simple but very practical. One main pipeline connect with fuel tank and fuel pump, which means there are two ways to collection fuel: firstly is pumping fuel directly through Fuel pump (suggest method); secondly is collection fuel from top Manhole.

At side of the truck which installed Fuel pump, also Fuel inlet & outlet valves (Pipeline system as below):

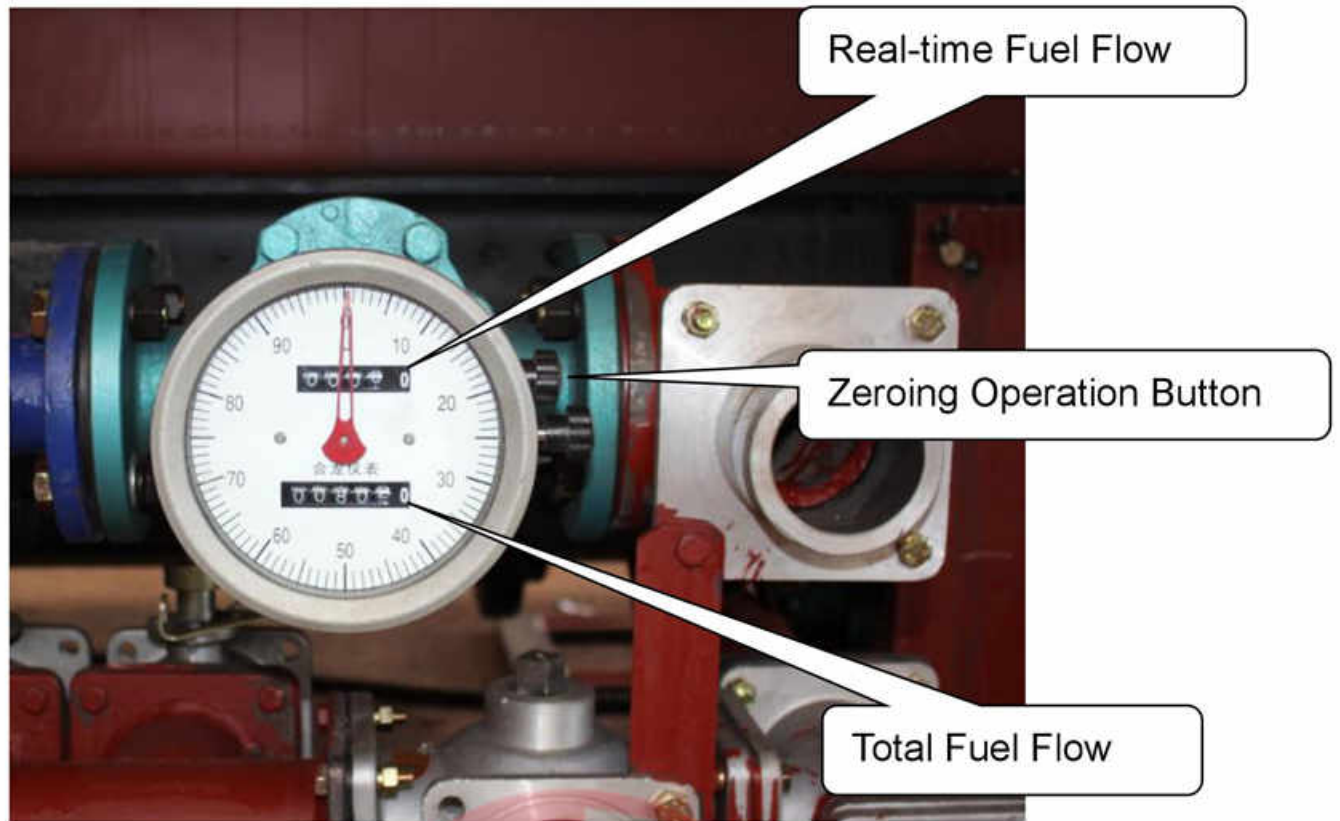

Scheme one: Record the Real-time Fuel Flow, which is dispensing flow.

Scheme two: Record the Total Fuel Flow, the dispensing flow is Difference for the first and second one

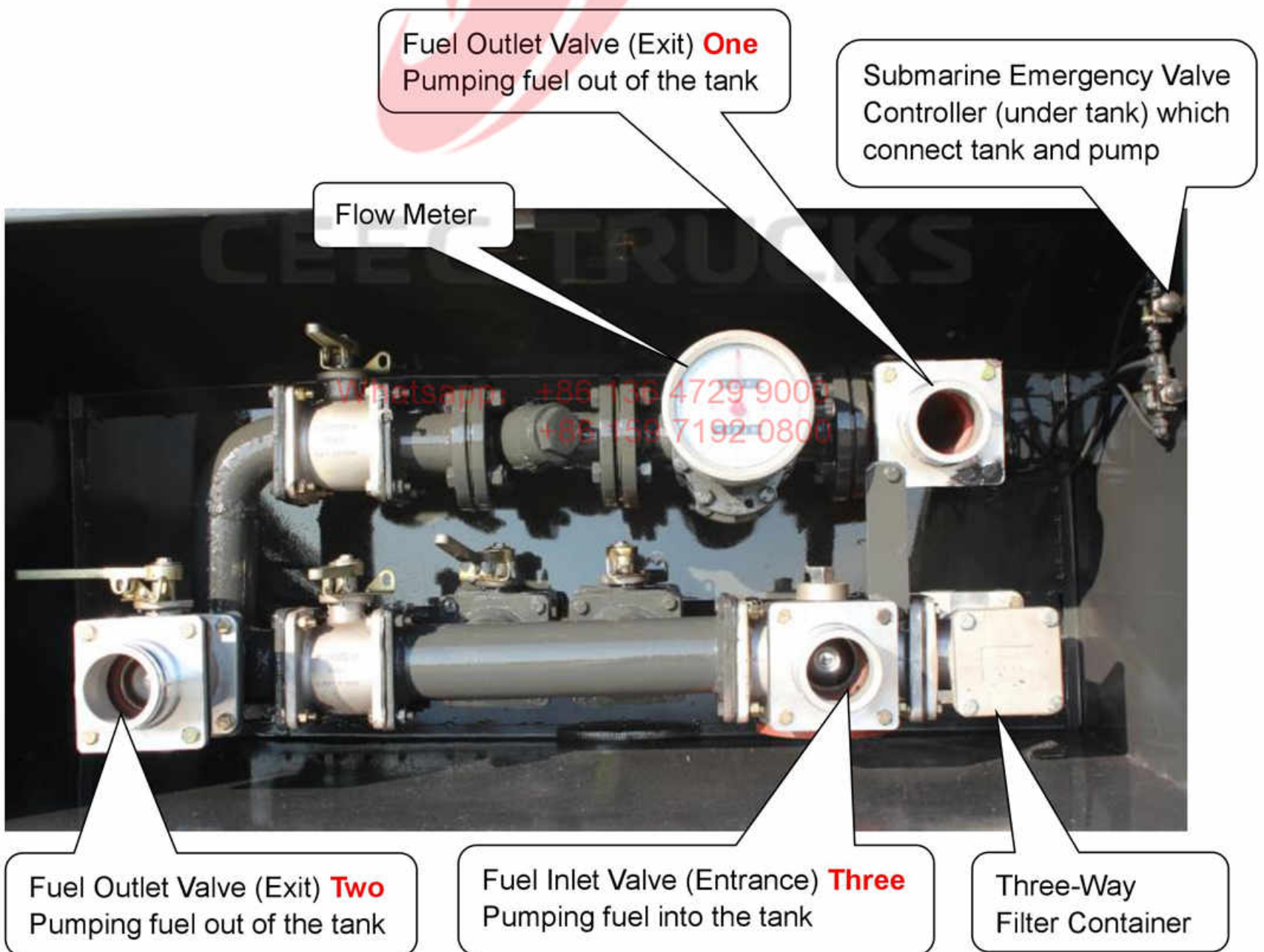

Chapter 5, Fuel Tanker Truck Working Principles

The operator should fully understand Whole Structure and Working Principle for BEIBEN Fuel Tanker Truck before any operation. Only trained person can operate this vehicle properly and to prevent unnecessary accidents and equipment damage.

i ,How are the fuel trucks working?

The BEIBEN Fuel Tanker Truck makes use of the special power take off (PTO) to get power from the engine, and then transfer the power to the Fuel Pump via drive axle so to rotate the pump. The fuel pump, pipelines, valves and joints consist of the pipeline system. Turn on/off valves through the regulated program, the pump can pumping-in fuel into the tank, also can pumping-out the fuel. As for the Flow Meter, this can be used record the flow of the fuel.

ii ,What is the main component for truck?

The fuel tanker truck is refitted based on the BEIBEN 6*4 LHD chassis. The refit part includes fuel carrying assembly, actuator device, pipeline system, operation system and flow record system.

- Fuel carrying assembly: A carbon steel container shaped ellipse, with anti-rust painting, which capacity can be up to 20,000Liter and be used to store and transport oil.
- Actuator device: includes power take off, drive line, etc., which can pass the power from the chassis to the pump.
- Pipeline system helps come to all special functions.
- Operation system: helps come to all special functions' convert.
- Flow record system: helps to record fuel flow volume.

iii, How to operate fuel tanker trucks?. **(Very Important)**

1, Refer to Chapter 4 and get more information about valves structure component.

**Please Note: When wrench is PARALLEL with pipeline, the pipe flow;
When wrench is VERTICAL with pipeline, the pipe closed.**

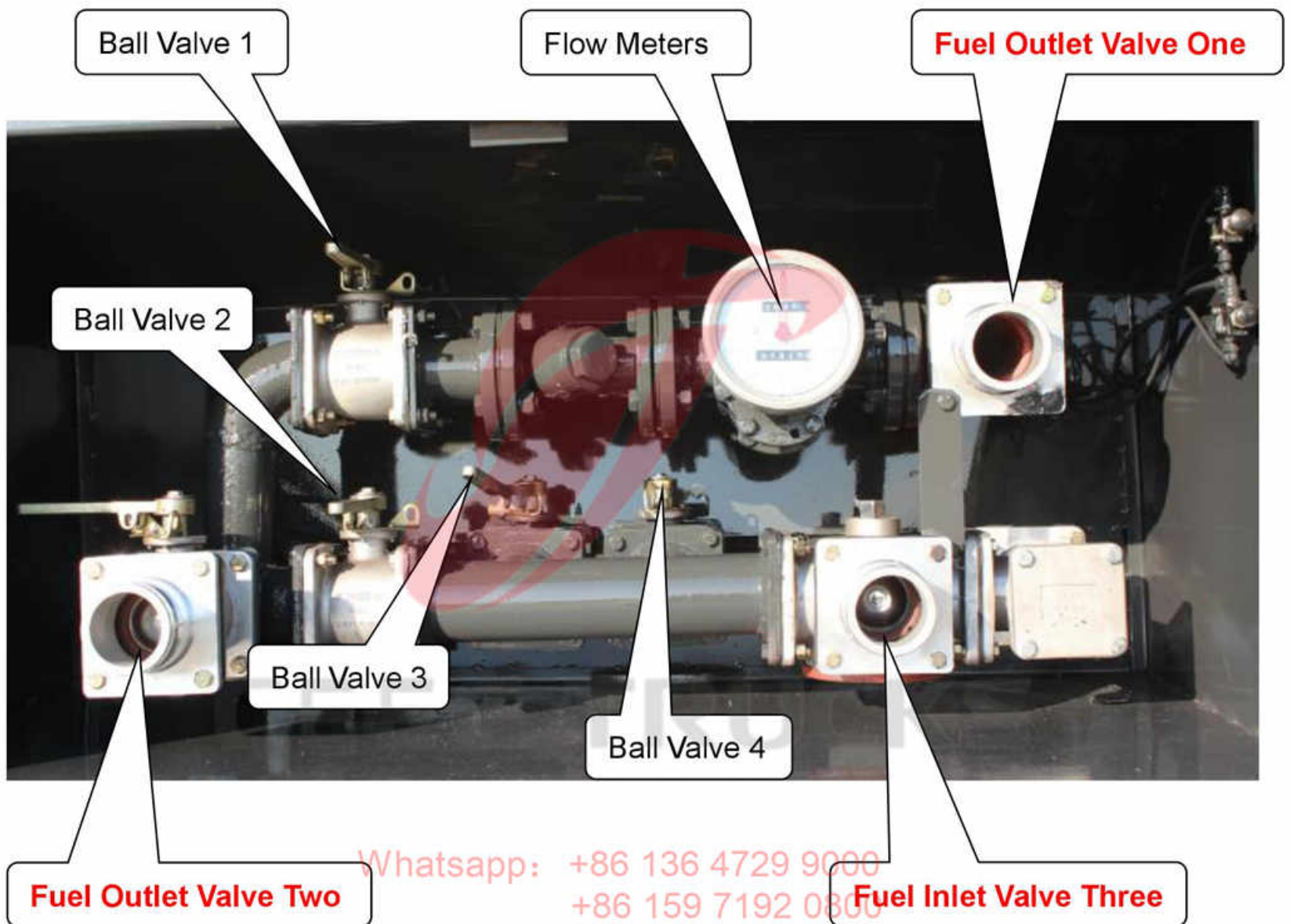

Fuel Outlet Valve One: Fuel Outlet Valve, Flow Meter working

Fuel Outlet Valve Two: Fuel Outlet valve, Flow Meter not working

Fuel Inlet Valve Three: Fuel Inlet Valve, Flow Meter not working

Ball Valve One, Two, Three, Four control the fuel flow in the pipeline system

2. Read the below Operation Chart carefully before any operation:

Double-Compartment Fuel Truck Pipeline System

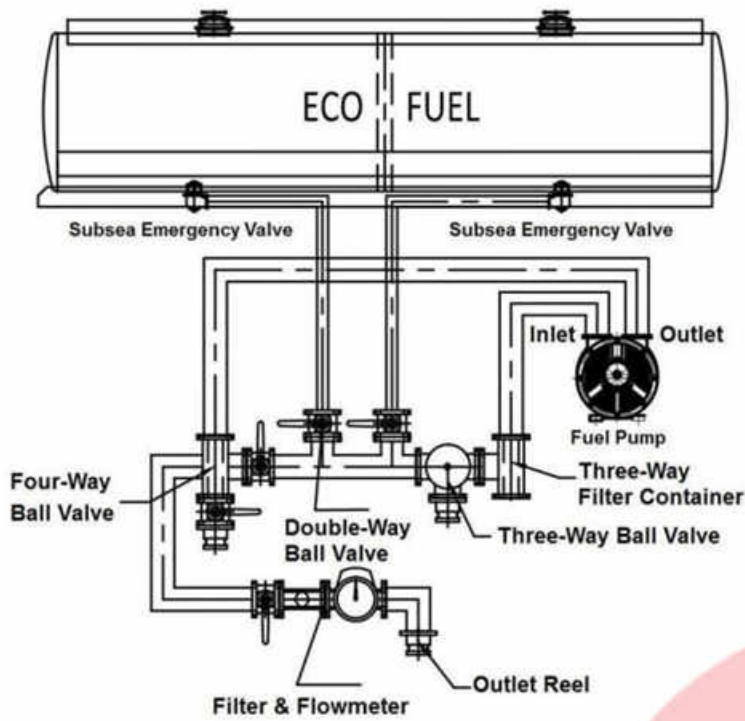

Schedule of Pumping-In Course

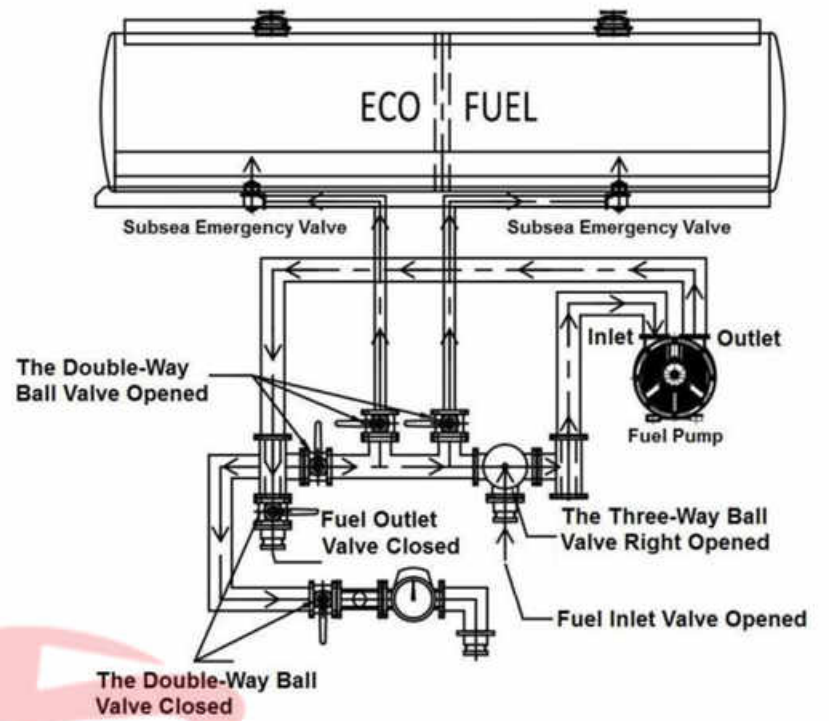

Schedule of Pumping-Out Course

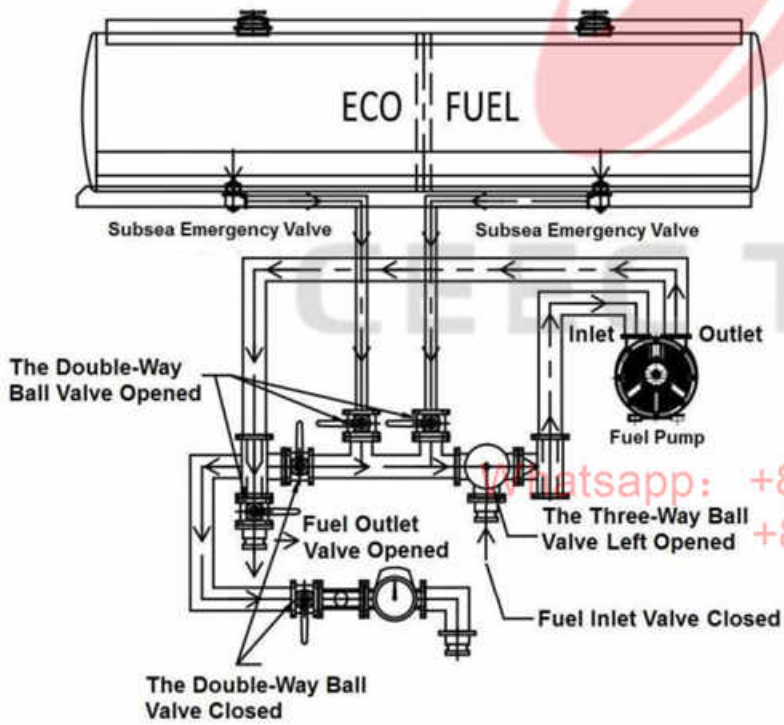

Schedule of Flowmeter for Pumping-Out

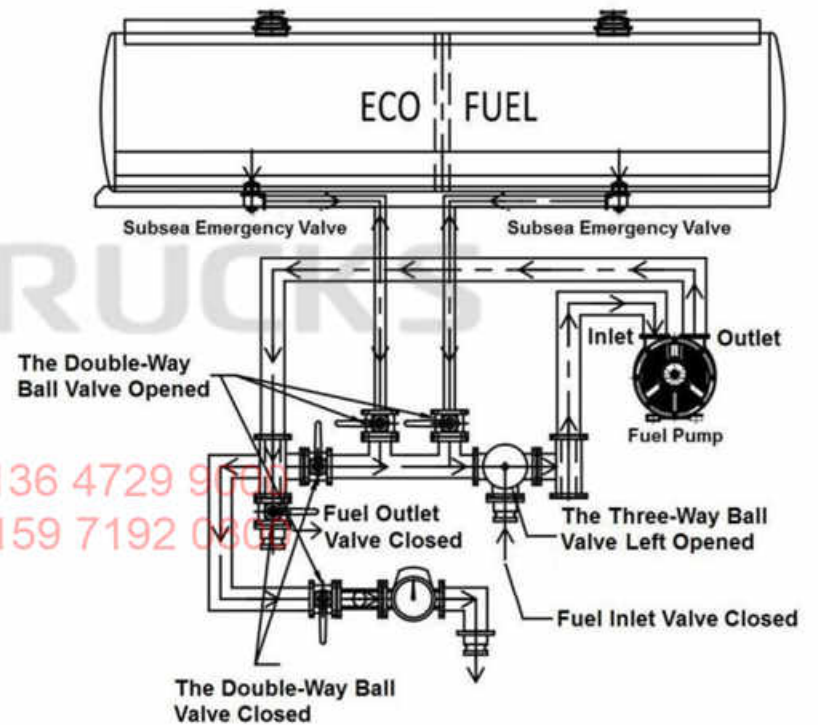

- a) Before operating valves you should operating the power take off (PTO), the truck transmission gearbox should be in neutral, when the engine is idle, step on the clutch pedal and turn the PTO switch on, and then release the clutch pedal slowly. The fuel pump will start operating.
- b) Before any other operation, the most important thing is opening the **Submarine Emergency Valve** controller, then the pump pipeline and the fuel tank is unblocked, and the oil can be pipping-in & pumping-out of tank.
- c) Special function operation showing as below, which mainly has following four functions:

➤ **Double-Compartment Fuel Truck Pipeline System:** There are mainly below 4 parts for fuel truck pipeline system.

Flow Meters: Consists of Flow meter indicator and fuel outlet valves

Fuel Pump: 80YHCB-60 fuel pump, provide power for fuel inlet & outlet of tank

Multi-Function Valves: Fuel Inlet Valve, Fuel Outlet Valve & Three-Way Ball Valve

Fuel Pipeline: Multiply fuel pipeline service for fuel transportation

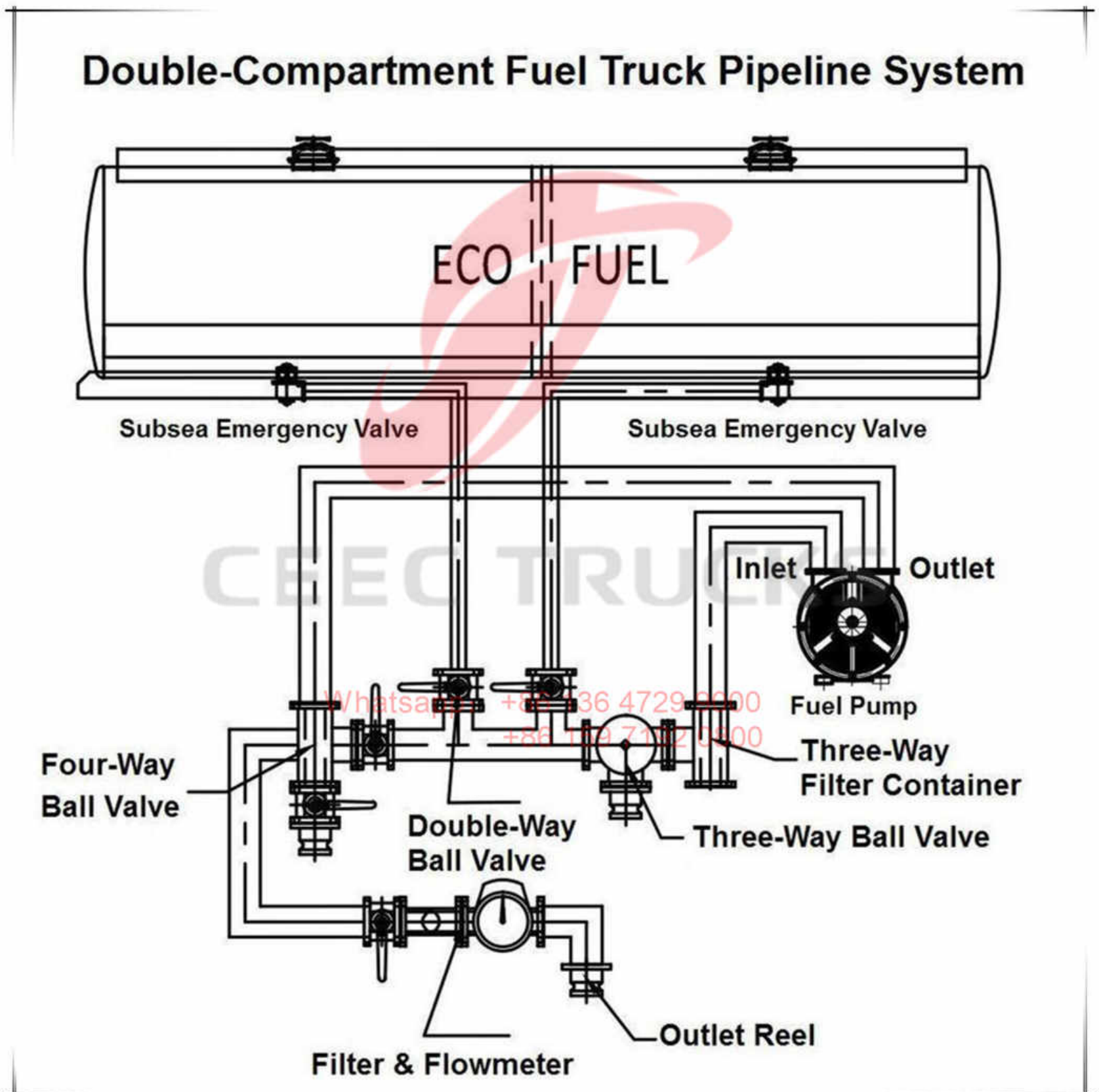

- **Schedule of Pumping-In Course:** open Fuel Inlet Valve Three, close Fuel Outlet Valve One & Two, close the Ball Valve 1 & Open Ball Valve 2, 3, 4 , open the Submarine Emergency Valve. Then oil sucked into the pump through Fuel Inlet Valve under negative pressure of fuel pump, then into the fuel tank. Details showing as below chart.

Schedule of Pumping-In Course

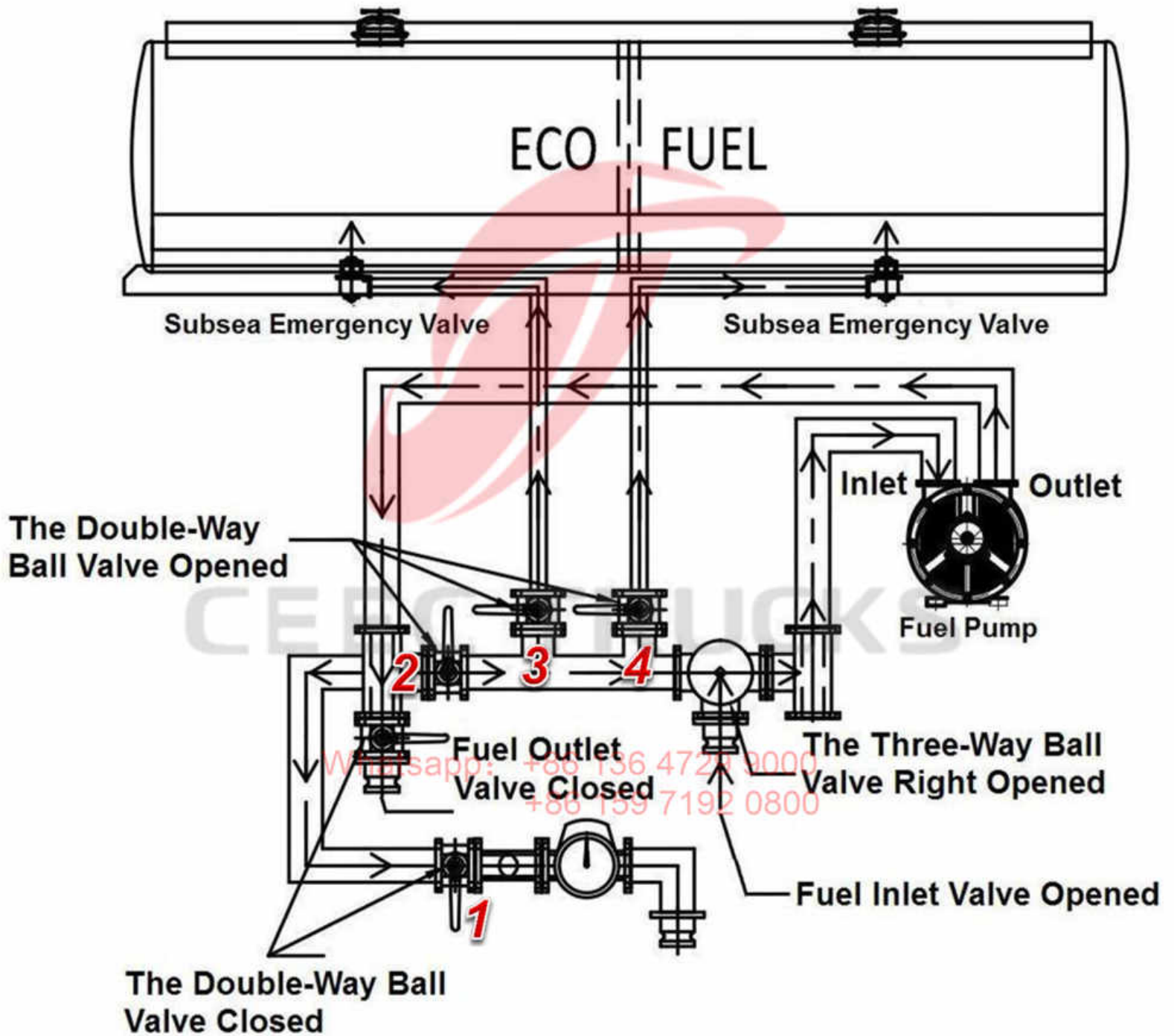

➤ **The Schedule of Pumping-Out Course:**

Oil flow out through Fuel Outlet Valve Two: open Fuel Outlet Valve Two, close Fuel Inlet Valve One & Three, Open Ball Valve 3, 4 & close the Ball Valve 1, 2, open the Submarine Emergency Valve. Oil pumping-out of the tank under negative pressure of fuel pump, and then flow out through Fuel Outlet Valve Two. Details showing as below chart.

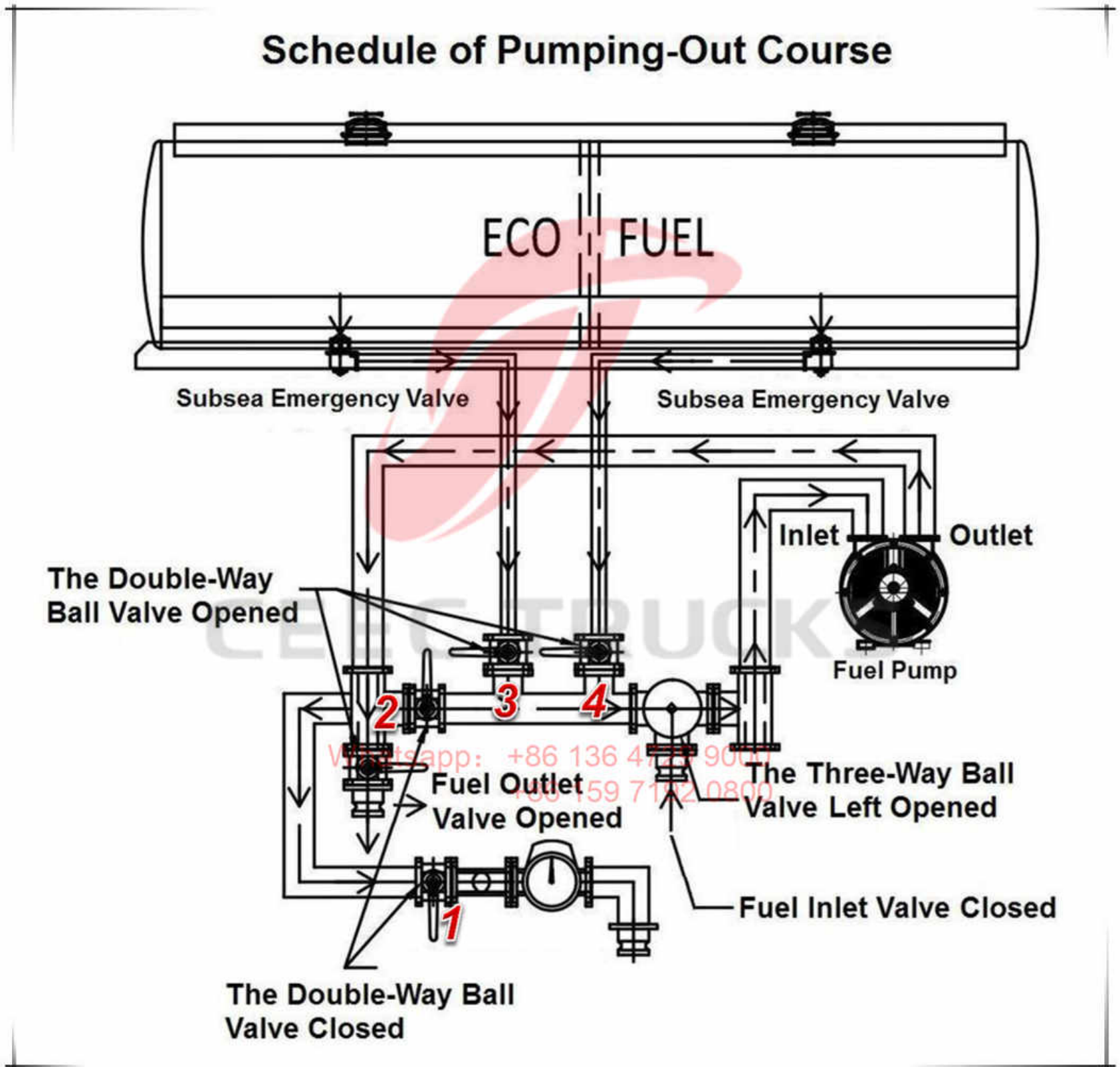

➤ **Schedule of Refueling Course:**

Oil flow out through Fuel Outlet Valve One: open Fuel Outlet Valve One, close Fuel Inlet Valve Two & Three, Open Ball Valve 1, 3, 4 & close the Ball Valve 2, open the Submarine Emergency Valve. Oil pumping-out of the tank under negative pressure of fuel pump, and then flow out through Fuel Outlet Valve One. and Flow Meters can record the flow volume. Details showing as below chart.

Schedule of Flowmeter for Pumping-Out

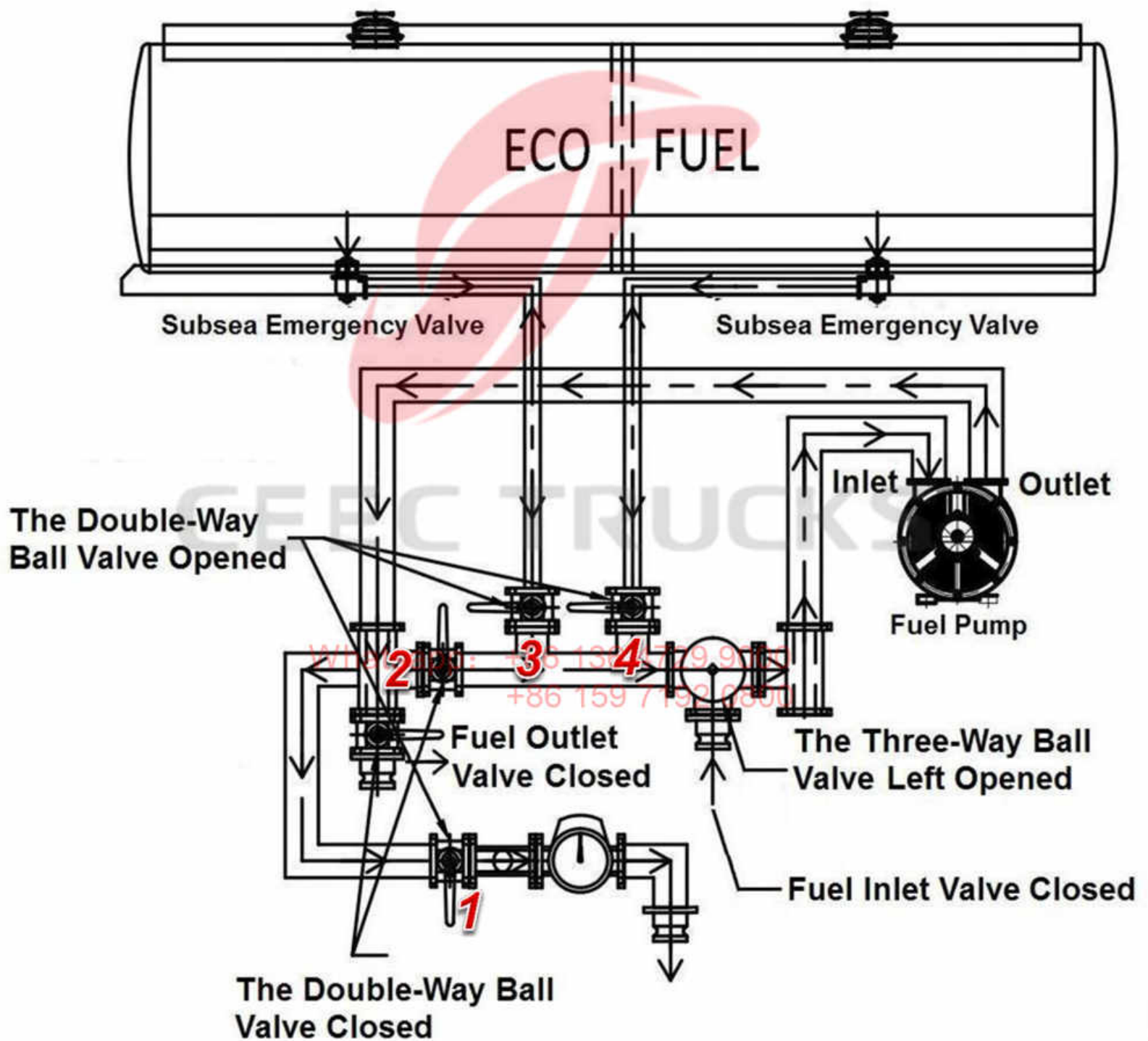

Chapter 6, Others for Attention

After carefully reading the above information, you must be well known how to use the ISUZU Fuel Tanker Truck; below show some parts you need to pay attention while using the truck.

i ,Precautions for Use

- Please abide strictly by the following two manuals:
 1. **Fuel Tanker Truck Owner's Manual**

- Carefully examination the fuel truck:
 1. Examine all parts, especially steering device, braking device, Suspension, tires and other joints, etc.
 2. Examine Exhaust Braking System, maintenance if have any leakage.
 3. Examine the tire pressure.
 4. Examine all lights on the truck, including Head Light, Fog Light, Turning Light, and Tail Light.
 5. Examine the rear Anti-Static tape, replace it if not tough the ground

- It is strictly forbidden to operate the Power Take Off (PTO) under the condition of the clutch not separation (Not step the clutch pedal). When release the clutch, you should slowly. The operation of the PTO must only on the condition of neutral for clutch.

- It is better not to do Half-Load transportation, especially for long-distance transport.

- When operating all the Valves, it is not good to overexert, for overexert will influence the valve ball's leakproofness. The open & close for Three-Way Valves should completely, and strictly forbidden working when valves not operated completely.

ii, Maintenance

- The maintenance of the chassis including clutch and transmission gearbox should be properly.
- The Maintenance of the fuel pump refers to the **"Fuel Tanker Truck Owner's Manual"**.
- It should be checked all coupling and lubrication at fixed period to exclude the tight parts, and make sure all parts in good lubrication condition.
- Both the Fuel Pump, PTO, Transmission Gearbox should be carefully washed, checked and maintenance every year.
- The strainer inside filter should be washed frequently. Exchange it if necessary.

iii, Spare Parts List

Item	Products Name	Quantity
1	6m long Fuel Pipeline	2 units
2	Standard Tools for chassis	1 set
3	Three-Way Valve Wrence	1 unit

Whatsapp: +86 136 4729 9000
+86 159 7192 0800